

# Magnet Extensometer

51817199

Copyright ©2002 Slope Indicator Company. All Rights Reserved.

This equipment should be installed, maintained, and operated by technically qualified personnel. Any errors or omissions in data, or the interpretation of data, are not the responsibility of Slope Indicator Company. The information herein is subject to change without notification.

This document contains information that is proprietary to Slope Indicator company and is subject to return upon request. It is transmitted for the sole purpose of aiding the transaction of business between Slope Indicator Company and the recipient. All information, data, designs, and drawings contained herein are proprietary to and the property of Slope Indicator Company, and may not be reproduced or copied in any form, by photocopy or any other means, including disclosure to outside parties, directly or indirectly, without permission in writing from Slope Indicator Company.

## ***SLOPE INDICATOR***

12123 Harbour Reach Drive  
Mukilteo, Washington, USA, 98275  
Tel: 425-493-6200 Fax: 425-493-6250  
E-mail: [solutions@slope.com](mailto:solutions@slope.com)  
Website: [www.slopeindicator.com](http://www.slopeindicator.com)

---

# Contents

Introduction .....	11
Installation .....	1
Taking Readings .....	1
Data Reduction .....	1

# Introduction

## Introduction

Magnetic extensometers are installed in boreholes or fills to monitor settlement and heave associated with construction, mining, and tunneling operations. Data obtained from the magnetic extensometer can indicate settlement zones as well as total displacement.

## Operation

The system consists of a probe, a steel measuring tape, a tape reel with built-in light and buzzer, and a number of magnets positioned along the length of an access pipe. The magnets are coupled to the surrounding soil and move up or down as heave or settlement occurs.

Readings are obtained by drawing the probe through the access pipe to find the depth of the magnets. When the probe enters a magnetic field, a reed switch closes, activating the light and buzzer. The operator then refers to the 1 millimeter or 0.01 foot graduations on the tape and notes the depth of the magnet.

When the pipe is anchored in stable ground, the depth of each magnet is referenced to a datum magnet that is fixed to the bottom of the access pipe. Settlement and heave are determined by comparing the current position of each magnet to its initial position.

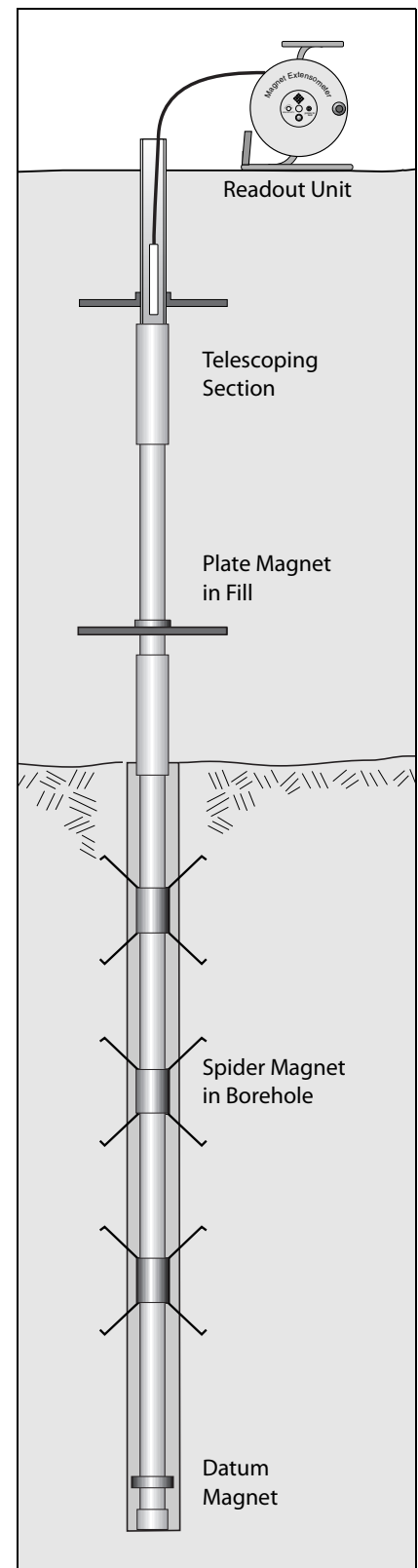

---

# Installation

## Extensometer Components

**Access Pipe:** Access pipe is available in three sizes: 1-inch, flush-coupled PVC pipe, and 2.75 or 3.34 inch inclinometer casing. Telescoping sections are required when settlement will exceed 2 or 3%.

**Datum Magnet:** The datum magnet is fixed directly to the bottom section of pipe to serve as a reference.

**Spider Magnet:** The spider magnet, named for its spring-steel legs, is used in boreholes. The legs are compressed for installation and released when the magnet is positioned at its specified depth. The spider magnet is typically attached to access pipe and installed with the pipe.

**Plate Magnet:** The plate magnet, used in fill, provides a broad surface area to couple with the soil.

## Installation Materials

- Nylon release cord for spider magnets
- Safety ties for spider magnets (cable ties or similar easy-release fastening device)
- Duct tape for spider magnets
- 1/8 inch hex wrench
- PVC or ABS cement for datum magnet
- Labeling pen and labels for release cords

---

**Overview:  
Installation in Borehole**

1. Mark magnets and inclinometer casing or access pipe with their intended depth.
2. Mark spider magnet release cords with the depth or magnet number.
3. Fix the datum magnet to the bottom section of casing.
4. Compress and attach spider magnets to pipe.
5. Install pipe.
6. Release compressed magnets.
7. Grout borehole.

**Overview:  
Installation in Fill**

1. If necessary, drill borehole into stable ground and follow steps above for installing magnets in a borehole.
2. Check that access pipe is vertical.
3. Install datum magnet (if not installed already).
4. Slide magnet onto pipe. Compact fill around magnet.
5. Continue extending casing through fill, adding plate magnets as required.

---

## Datum Magnet

The datum magnet is used when the bottom of the pipe is anchored in stable ground. It consists of the magnet itself and two retaining rings.

The datum magnet is usually installed at least 0.5 meter or 2 feet above the bottom of the pipe. For maximum security, lock rings and magnet can be cemented to the pipe with PVC solvent cement. For inclinometer casing, use ABS solvent cement.

1. Select one section of pipe and label it bottom.
2. Mark desired location of datum magnet.
3. Slip datum magnet onto pipe. Position magnet at marked location and tighten set screws.

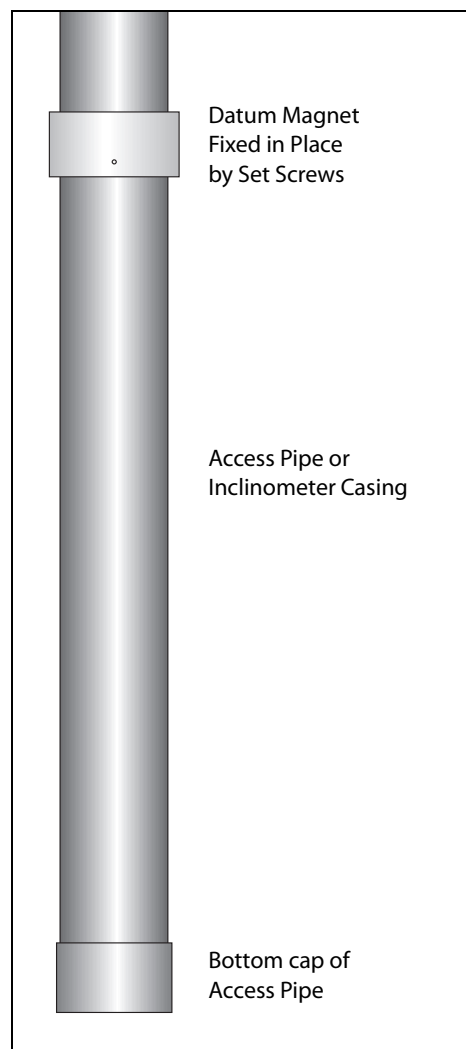

## Spider Magnets

Spider magnets must be securely attached to the pipe so that they reach their required locations as the pipe is installed. After the pipe is installed, the spring steel legs of the spider magnet are released to couple it to the surrounding ground at that elevation.

### Prepare Pipe

1. Mark pipe sections for order of installation. The mark a location for each magnet. Avoid locations near couplings.
2. Cut notches into pipe 248mm (9.75") above and below magnet location mark. Notches should be less than 1mm deep (1/32") so pipe is not weakened. Notches help prevent movement of magnet during installation.
3. Apply grease to pipe between upper and lower notches.

### Prepare Spider Magnets

1. Slide the first spider magnet to its marked location.
2. Compress legs and bind them temporarily with safety ties. Handle compressed legs with care. An accidental release could cause injury. Note that safety ties will be removed just before installation.
3. Prepare release cord of sufficient length to extend between intended magnet depth and surface. Allow a minimum of 3m (10ft) of extra cord for surface handling. Label the top end of cord with magnet number or depth. Attach the bottom end of cord to release pin.
4. Wrap compression wire around upper legs of spider magnet. Push release pin through the loop formed by the compression wire. Then push release pin through guide hole in magnet body. Wrap a second compression wire around lower legs of magnet and push release pin through the loops.

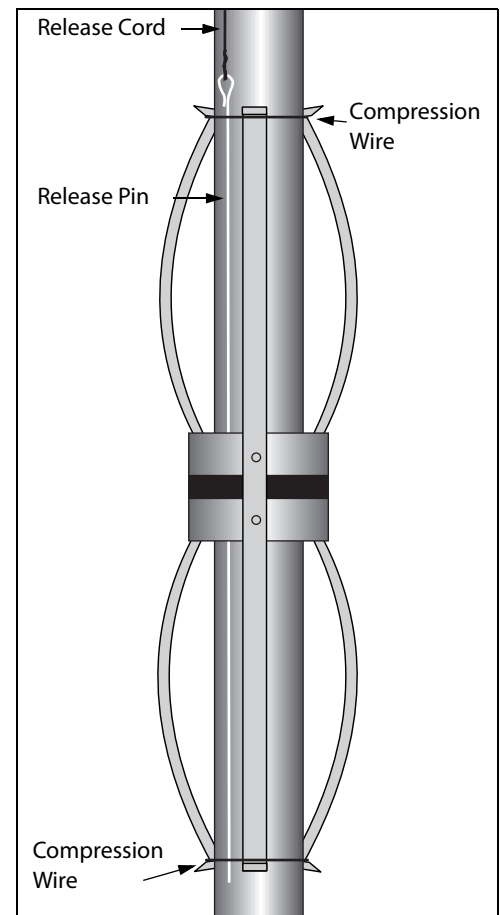
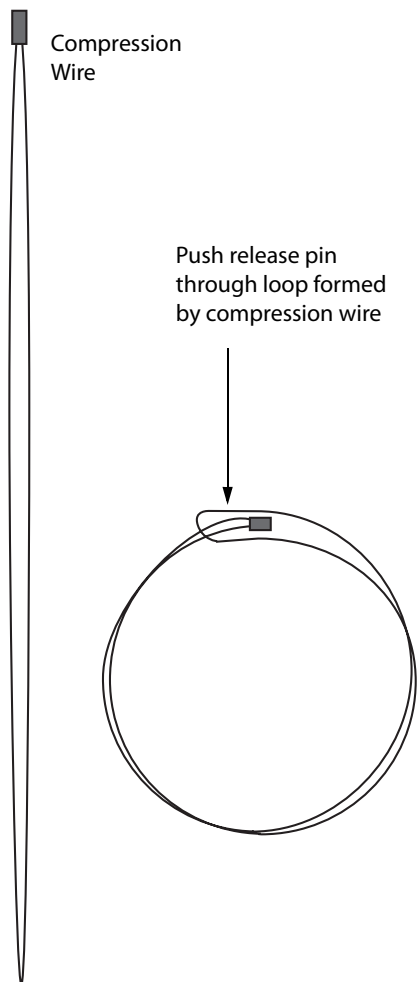

5. Check that compression wires are seated in notches. Adjust location of wire, if necessary. Fix top and bottom of release pin to pipe with one wrap of vinyl tape, to prevent premature release during installation.
6. Coil release cord and tape to pipe.
7. Repeat for other spider magnets.

### Install Pipe and Spider Magnets

1. Check that pipe sections are marked for order of installation, magnets are fixed to each section of pipe, and release cords are labeled, coiled and taped to pipe sections.
2. Select bottom section of pipe. Check that datum magnet is securely fixed to pipe. Install in borehole. Follow normal procedures for couplings.
3. Select next section of pipe and couple. Remove safety ties from magnet legs. Safety ties must be removed with care, keeping hands and eyes out of the path of the legs.
4. Uncoil release cord and lay out in straight line. Check that cord will not be snagged, since this could release legs prematurely. Plan to lay out release cords from other magnets as well and take care to avoid tangling cords. If possible, assign someone to feed cords down hole as pipe is lowered.
5. Repeat steps 2 and 3 until pipe reaches bottom of borehole.

### Release Legs of Spider Magnets

1. Check depth of each magnet using magnetic extensometer probe (see Taking Readings).
2. Pull drill casing, if used, to an elevation that is above the upper legs of the deepest magnet. If legs are released into drill casing, the entire installation will have to be replaced.
3. Release legs of the magnet, pulling upwards on release cord.
4. If necessary, pull drill casing above next magnet. Then pull release cord to release the legs. Repeat this step until all spider magnets are anchored.
5. Backfill borehole with a soft bentonite-cement grout as specified by project engineer.

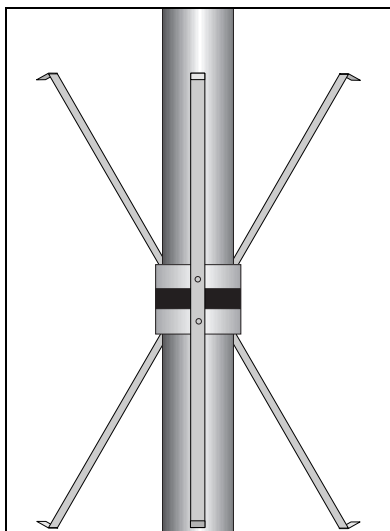

---

## Installing Plate Magnets

Plate magnets are installed where the access pipe will pass through fill.

1. Pipe should be held vertical. Compacted fill around pipe should be at specified elevation for first plate magnet.
2. Slide plate magnet down pipe to rest on fill.
3. Cover magnet with fill material and compact to the same specifications as the surrounding fill.
4. Add pipe sections and magnets as level of fill is raised. Keep debris from entering access pipe.

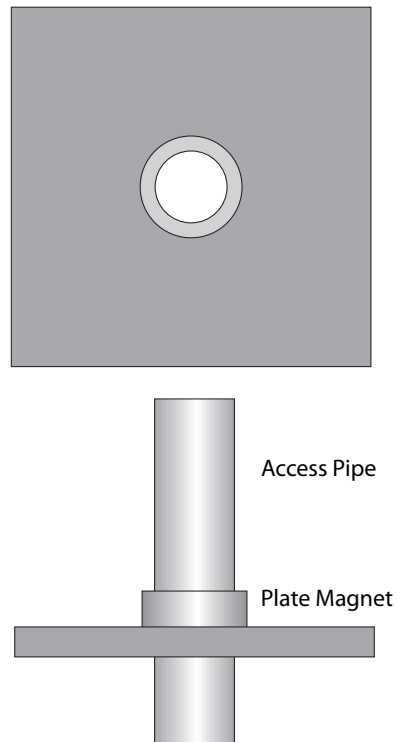

---

# Taking Readings

- General Concerns** For consistent results, be sure that all technicians maintain the same reading procedures throughout the project.
- Use the same probe for each installation. If different probes must be used in the same installation, take an initial reading with each probe and compare data. Apply any offset to later readings.
- Initial Readings** Obtain a set of initial readings. Because the initial readings are particularly important, it is recommended that the user obtain three sets of readings from three separate passes through the pipe. Average the readings for each magnet. Alternatively, find two sets that are very close and use one of them as the initial set.
- Taking Readings**
1. Switch probe power on.
  2. Lower probe to bottom of pipe. Raise probe until buzzer sounds. Then slowly raise probe until buzzer sounds a second time. Use the first buzz to find the general location of the magnet. Use the second buzz to determine exact location of magnet. Depth of magnet is found by reading tape. Note depth of magnet on field data sheet.
  3. Raise probe to next magnet. Always read tape on second buzz. Repeat until depth of each magnet has been recorded.

---

# Data Reduction

**Field Data** When we take readings, we use the top of the access pipe to index the depth of the probe. So field data is referenced to the top of the pipe, rather than to the datum.

The table below shows the measured depths of five magnets over a period of six months. The magnets were initially spaced about 5 feet apart.

Magnet	Field Data					
	Set 1	Set 2	Set 3	Set 4	Set 5	Set 6
5	20.57	20.55	20.51	20.33	20.28	20.26
4	25.63	25.60	25.55	25.34	25.28	25.26
3	30.64	30.60	30.54	30.29	30.23	30.21
2	35.59	35.55	35.48	35.20	35.14	35.11
1	40.62	40.57	40.50	40.20	40.13	40.10
Datum	45.58	45.53	45.46	45.14	45.07	45.04

**Inverting the Reference** Before we can calculate settlement, we must “invert” the reference so that readings are the distance from the datum magnet rather than the distance from the top of the access pipe. We invert the reference because the datum magnet is assumed to be in stable ground while the top of the access pipe is assumed to be settling.

The table below shows the initial reading on Month 1 referenced to the datum magnet. The measured depth of each magnet was subtracted from the measured depth of the datum magnet.

Magnet	Set 1
5	25.01
4	19.95
3	14.94
2	9.99
1	4.96

Magnet #1 is now shown to be 4.96 feet above the datum magnet, magnet #2 is 9.99 feet above, and so on.

Note: If you must use the top of the pipe as the reference because the bottom is not stable, you must survey the pipe optically and then add or subtract offsets obtained from the survey.

---

## Calculating Settlement and Heave

The data summary below shows the initial reading, current magnet elevations, and changes, referenced to the datum magnet.

The Current value is calculated by inverting the reference as discussed in the step above. It is the distance of each magnet from the datum magnet.

The Change value is the difference between the current depth and the initial depth of each magnet. A positive value indicates settlement and a negative value indicates heave.

Data Summary											
	Set 1	Set 2		Set 3		Set 4		Set 5		Set 6	
Magnet	Initial	Current	Change	Current	Change	Current	Change	Current	Change	Current	Change
5	25.01	24.98	0.03	24.95	0.06	24.81	0.20	24.79	0.22	24.78	0.23
4	19.95	19.93	0.02	19.91	0.04	19.80	0.15	19.79	0.16	19.78	0.17
3	14.94	14.93	0.01	14.92	0.02	14.85	0.09	14.84	0.10	14.83	0.11
2	9.99	9.98	0.01	9.98	0.01	9.94	0.05	9.93	0.06	9.93	0.06
1	4.96	4.96	0	4.96	0	4.94	0.02	4.94	0.02	4.94	0.02