

VW 3-D Jointmeter

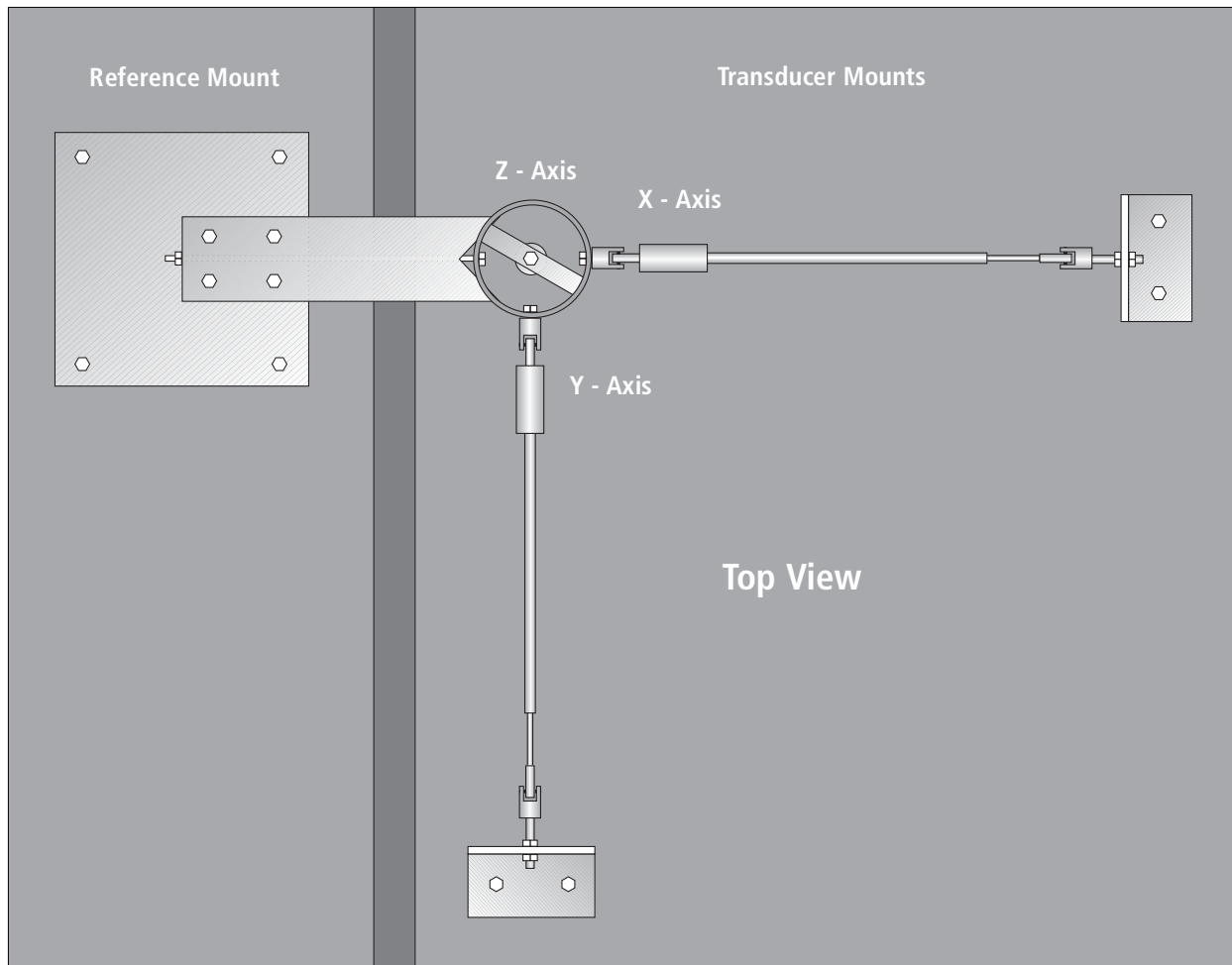

Applications

The VW 3-D jointmeter is used to monitor movement at joints and cracks. Designed to withstand extended submersion, the jointmeter is suitable for applications such as:

- Monitoring movement at submerged construction joints in concrete-face dams.
- Monitoring joints or cracks in tunnels and tanks.

Operation

The jointmeter consists of 3 waterproof VW displacement transducers, the 3-D mounting system, and groutable anchors.

The groutable anchors are installed on opposite sides of the joint. The mounting system is secured to the anchors, and the VW displacement transducers are positioned to provide the required range. Signal cables from the sensors are routed to a readout station.

A VW indicator or data logger is used to read the transducers. The initial reading serves as a datum. Subsequent readings are compared to the initial to calculate the magnitude and rate of changes.

Advantages

Submersible: The jointmeter is rated for 17 bar (250 psi) of water pressure.

Multi-Axis Monitoring: The jointmeter monitors the X, Y, and Z axes.

Easy Installation: Installation requires small, shallow drill holes in the concrete slab.

Manual or Automatic Readings: The jointmeter is easily connected to a data logger for unattended monitoring.

3D JOINTMETER COMPONENTS

The VW 3-D Jointmeter consists of several components that are ordered separately. Required components include three VW displacement sensors, signal cable for the sensors, and one 3-D mounting system. Accessories include anchors and a reusable mounting template.

3-D MOUNTING SYSTEM

Sensor Mount and Target52632205

Three aluminum brackets, six universal joints, and necessary hardware. Does not include anchors.

Overall dimensions of the 3-D jointmeter, with transducers, are: 965mm deep, 790 mm wide, and 520 mm high (38" x 31" x 20.5").

Anchor Kit52632210

Nine M10x 250mm stainless steel all-thread anchors with washers and nuts. Does not include epoxy grout.

Drilling Template52632206

Reusable template aids placement of drill holes for anchors.

VW DISPLACEMENT TRANSDUCER

60 mm VW Transducer 52636388

Type: Vibrating wire.

Range: 60 mm.

Resolution: 0.025% FS.

Calibration Accuracy: $\pm 0.1\%$ FS.

Repeatability: $\pm 0.5\%$ FS.

Non-Linearity: $< 0.5\%$ FS.

Temperature Rating: -20 to + 80°C.

Waterproof Rating: 17 bar (250 feet).

SIGNAL CABLE

Signal Cable 50613524

Order signal cable for each transducer. Shielded cable with four 22-gauge, tinned copper conductors and polyurethane jacket.

READOUTS

Readouts

VW Data Recorder and other pluck-type VW readouts. See separate data sheets for details.

Universal Terminal Box57711600

Optional terminal box provides connections for 12 sensors and an indicator. Sensors selected by rotary switch. Weatherproof fiberglass box measures 290 mm wide x 345 mm high x 135 mm deep (11.5 x 13.5 x 5.25").

Universal Connector57705001

Optional connector. Not required for terminal box or data logger.

DATA LOGGERS

Data Loggers

Campbell Scientific CR10X data logger with a VW interface and an AM16/32 multiplexer can accommodate 16 jointmeters with temperature readings or 32 jointmeters without temperature readings. See separate data sheet.

